

# **USERS GUIDE**

---

# **KM 529 LCD**



## Content

Preface .....	1
1. Appearance and Size .....	2
1.1 Material and Color .....	2
2. Function and Button Definition .....	3
2.1 Functional Description .....	3
2.2 Monitor Area .....	3
2.3 Button Definition .....	3
3. Precautions .....	4
4. Installation Instructions .....	4
5. User settings .....	4
5.1 Power On/Off .....	4
5.2 Current Speed/Average Speed/Max Speed .....	4
5.3 Mileage Display .....	5
5.4 PAS Level Selection .....	5
5.5 Walk Assist Mode .....	6
5.6 Headlight On/Off .....	6
5.7 Battery Indicator .....	6
6. Error Code .....	7
7. User settings .....	7
7.1 Preparation before boot .....	7
7.2 General settings .....	8
7.2.1 Wheel Size Setting .....	8
7.2.2 Speed limit setting .....	8
7.2.3 Backlight brightness setting .....	9
8. FAQ .....	9
9. Quality assurance and warranty scope .....	9
10. Version .....	10
Appendix 1: Error Code Definition .....	11

## **Preface**

To ensure better performance of your e-bike, please read through the KM529 LCD product introduction carefully before using it. We will use the brief words to inform you of all the details (including hardware installation, setting and normal use of the display) when using our display. Meanwhile, the introduction will also help you solve possible confusion and barriers.

## 1. Appearance and Size

### 1.1 Material and Color

KM529 product is made of plastic (PC) materials, the working temperature scope of the housing material is  $-20^{\circ}\text{C}$ — $+60^{\circ}\text{C}$ , the shell material can ensure normal use and good mechanical performance of the products.

Display Dimensions (Unit: mm)

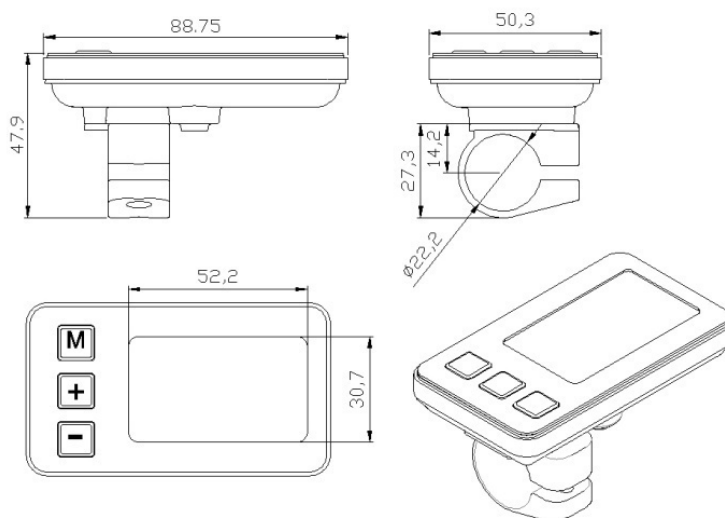

## 2. Function and Button Definition

### 2.1 Functional Description

- ◆ Battery indication
- ◆ speed display (including real-time speed , maximum speed and average speed)
- ◆ Mileage display (including Trip and ODO)
- ◆ PAS level
- ◆ Headlight on and off
- ◆ Error Code Display
- ◆ Multiple setting parameters: wheel size, speed limit, backlight brightness

### 2.2 Monitor Area



### 2.3 Button Definition

KM 529 display has three buttons. including “BOOT/MODE” key, “PLUS” key and “MINUS” key.

For subsequent instructions, the button  is replaced by a text “MODE”.  Key is replaced by a

text "UP",  key is replaced by a text "DOWN"

## 3. Precautions

Take care when using the display and do not connect/disconnect it while the power is on.



Avoid striking or knocking the display.



Do not remove the waterproof film attached to the display as this may impair its waterproofing.



Don't modify system parameters to avoid parameters disorder.



In the case of errors or malfunctions the display should be returned to your local supplier for repairs/replacements.

## 4. Installation Instructions

Fix the display onto the handlebar and adjust to an appropriate visual angle when power off the E-bike, plug the connector of the display in the corresponding connector of the controller to complete the installation.

## 5. User Settings

### 5.1 Power On/Off

Long hold **[MODE]** button, the display will power on, also power on the controller. When the display on, hold **[MODE]** for a while to turn off power supply of the e-bike. When the display off, the display will not use any power from battery. The leakage current is less than 1 uA.



When not using e-bike for more than 10 minutes, the display will turn off automatically.

### 5.2 Current Speed/Average Speed/Max Speed

After the display is powered on, the display will show the current speed by default. Long press **[MODE]** and **[UP]** buttons to switch display information. The sequence of display is: Current speed (unit: Km/h) → Average speed (unit: Km/h) → MAX speed of the ride (unit: Km/h).



Current speed display

Average speed display

Maximum speed display

## 5.3 Mileage Display

After the display is powered on, the display will show the ODO by default.. Click [MODE] to switch display information. The sequence of display is Trip (unit: km)→ ODO (unit: km).

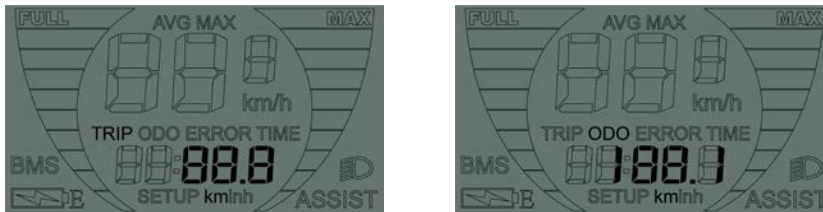

Single mileage (TRIP) shows cumulative mileage (ODO) display



Long press the [MODE] and [DOWN] keys, and the Trip will be cleared.

## 5.4 PAS Level Selection

Short press the[UP] or [DOWN] button to switch the PAS level, the motor output power will be changed accordingly by the PAS level of E-bike. The default range of PAS level is 1-5 levels. The minimum power level is 1 and the max power level is 5.The default start up level is level 1.

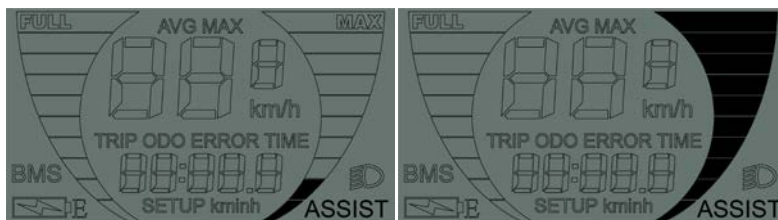

LEVEL1

MAX LEVEL

## 5.5 Walk Assist Mode

Press and hold the [DOWN] key for 2 seconds without lifting it to start the Walk Assist mode.

The motor outputs power at a speed of about 6KM/H for special needs such as uphill promotion.



Walk Assist Mode



The walk assist mode can only be used when the user is pushing the E-bike. Do not use it when riding

## 5.6 Headlight On/Off

Long press the [UP] button, the backlight will be turned on, and the controller will be informed to turn on the headlight. The LCD headlight can be turned on when the external light is insufficient or when driving at night. Long press the [UP] button for 2 seconds again to turn off the backlight and inform the controller to turn off the headlight.

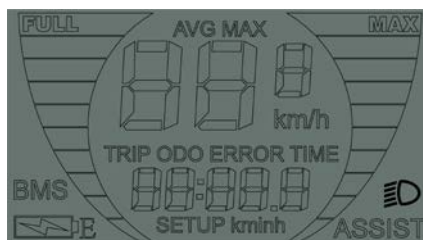

Headlight on Interface

## 5.7 Battery Indicator

When the battery power is the highest, the power display full grid. When the battery capacity is insufficient, the letter "E", power indicator appears below the screen, indicating that the battery is undervoltage and needs to be charged immediately.



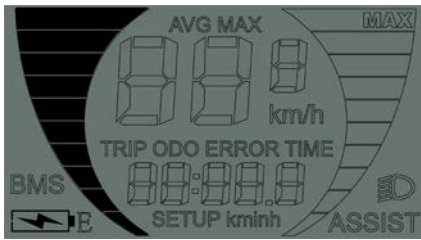

Maximum power display

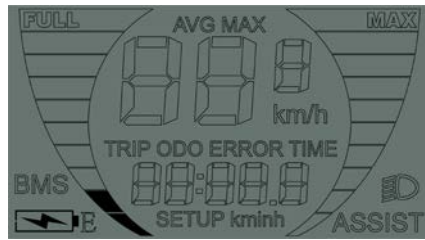

Low Power Display

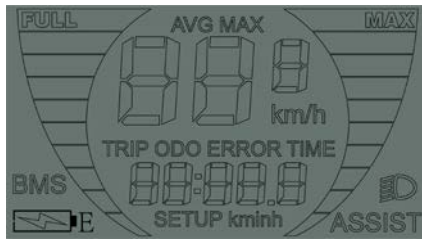

Undervoltage flashing

## 6. Error Code

When the E-bike electric system fails, the display will automatically show the error code. Please refer to the error code Appendix 1.



Error code interface

## 7. User Settings

### 7.1 Preparation Before Boot

Ensure that the connectors are firmly connected, and turn on the power of the e-bike.

## 7.2 General Settings

Long press the MODE button to boot. Under boot state, hold down the **[UP]** and **[DOWN]** buttons for 2 seconds to enter into the settings mode.

### 7.2.1 Wheel Size Setting

Diameter setting :16 inch 、18inch 、20inch 、22inch 、24inch 、26inch 、700C,28inch. The default wheel size is 26 inches. Press **[UP]**or **[DOWN]** to switch the wheel diameter, press the **[MODE]**button to confirm the selection of the Ebike's corresponding wheel diameter, and enter the next setting.



Wheel size setting Interface

### 7.2.2 Speed Limit Setting

Speed limit settings can set the maximum riding speed of E-bike. When the speed of E-bike exceeds the set value, the controller will stop the output of the motor to protect the rider from driving safely. The optional range of maximum limit speed setting values is 12 Km/h to 40 Km/h. The default limit riding speed setting of the display is 25Km/h. Press **[UP]** or **[DOWN]** to adjust the value, press **[MODE]** button to confirm, and enter the next setting.



Speed limit setting interface

## 7.2.3 Backlight Brightness Setting

Backlight settings can set 3 backlight brightness. Set parameters 1,2,3 to indicate backlight brightness level ,1 is darkest ,2 is standard brightness, and 3 is brightest. The default value of the display is 1. Press **[UP]** or**[DOWN]** to change the backlight brightness parameter, press **[MODE]** button to confirm.



Backlight Setup Interface

## 8. FAQ

Q: Why can't turn on the display?

A: Please check whether the battery is turned on or the leakage lead wire is broken

Q: How to deal with the error code display?

A: Contact the e-bike maintenance station in time.

## 9. Quality Assurance and Warranty Scope

### I 、 Warranty

1、 Any quality problems in normal case and during guarantee period, our company will be responsible for the warranty.

2、 The warranty time is 24 months when display out of the factory.

### II 、 Other items

The following items do not belong to our warranty scope.

1、 It can not be demolished.

2、 The damage is caused by wrong installation or operation.

3、 Shell is broken when display is out of the factory.

4、 Wire is broken.

5、 The fault or damage is caused by the force majeure (such as fire, earthquake, etc,) or natural disasters like lightning, etc.

6、 Beyond Warranty period.

## **10. Version**

This display manual is the general software version (version 1.0) of Tianjin King-Meter Technology Co., Ltd. When there is slight difference between this software version during using e-bike and this manual, which should depends on the actual use version.

**Appendix 1: Error Code Definition**

Error code	Definition
21	Current Abnormal
22	Throttle Abnormal
23	Motor phase problem
24	Motor Hall defect
25	Brake Failed
30	Abnormal Communication
31	Boot button adhesion
34	6 km Functional button adhesion

***KING-METER***

**KING-METER TECHNOLOGY CO.,LTD**

No.15,Chenchang Road,Beichen Dist.Tianjin ,300134,CN

Fax : +0086 022 8478 0358Tel: +0086 022 8478 0378

---

***KING-METER***